

FLOW, NEEDLE & CHECK VALVES

HYDRAULIC BALL VALVES

WELD COUPLINGS

FLANGES

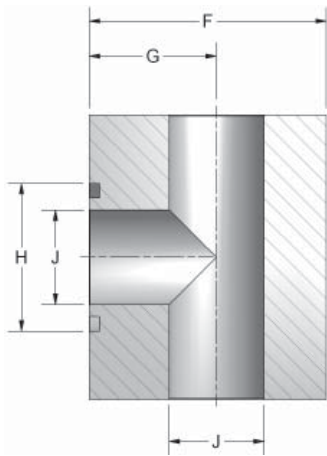

Figure 1

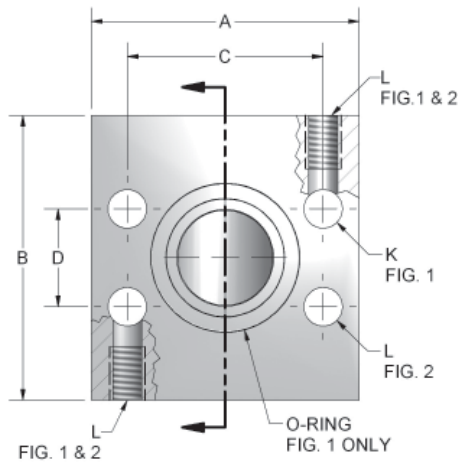

Figure 2

CODE 61 TEE JUNCTION BLOCK															
PART NO. O-RING FIG. 1	PART NO. FLAT FACE FIG. 2	PAD SIZE	A	B	C	D	E	F	G	H	J	K	L UNC-2B	MOUNTING HARDWARE	
														O-RING	SHCS
W17-12	W16-12	.75	2.62	2.75	1.875	.875	1.38	2.25	1.22	1.250	.75	.406	3/8-16	214	3/8-16X3.00
W17-16	W16-16	1.00	2.82	3.00	2.062	1.031	1.50	2.50	1.34	1.560	1.00	.406	3/8-16	219	3/8-16X3.25
W17-20	W16-20	1.25	3.19	3.50	2.312	1.188	1.75	3.00	1.56	1.750	1.25	.469	7/16-14	222	7/16-14X4.00
W17-24	W16-24	1.50	3.75	4.00	2.750	1.406	2.00	3.50	1.88	2.115	1.50	.531	1/2-13	225	1/2-13X4.50
W17-32	W16-32	2.00	4.00	4.25	3.062	1.688	2.12	4.00	2.09	2.490	2.00	.531	1/2-13	228	1/2-13X5.00

CODE 62 TEE JUNCTION BLOCK															
PART NO. O-RING FIG. 1	PART NO. FLAT FACE FIG. 2	PAD SIZE	A	B	C	D	E	F	G	H	J	K	L UNC-2B	MOUNTING HARDWARE	
														O-RING	SHCS
W19-12	W18-12	.75	2.81	3.00	2.00	.937	1.50	2.50	1.310	1.250	.750	.406	3/8-16	214	3/8-16X3.25
W19-16	W18-16	1.00	3.19	3.50	2.25	1.093	1.75	3.00	1.620	1.560	1.000	.492	7/16-14	219	7/16-14X4.00
W19-20	W18-20	1.25	3.75	4.00	2.625	1.250	2.00	3.50	1.880	1.750	1.250	.531	1/2-13	222	1/2-13X4.50
W19-24	W18-24	1.50	4.50	4.50	3.125	1.437	2.25	4.00	2.120	2.115	1.500	.656	5/8-11	225	5/8-11X5.00
W19-32	W18-32	2.00	5.25	5.00	3.812	1.750	2.50	5.00	2.750	2.490	1.940	.781	3/4-10	228	3/4-10X6.00