

Figure 1

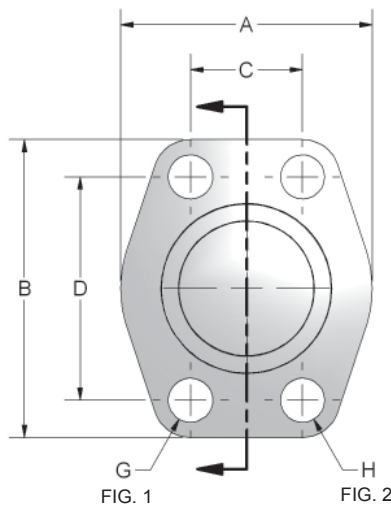

FIG. 1

FIG. 2

PILOT HOLE
PRESENT ONLY ON
FLAT FACE PARTS

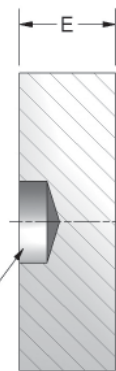
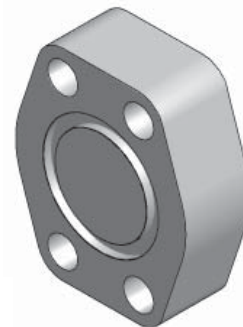

Figure 2



CODE 61 BLANKING												
PART NO. O-RING FIG. 1	PART NO. FLAT FACE FIG. 2	PAD SIZE	A	B	C	D	E	F	G	H UNC-2B	MOUNTING HARDWARE	
											O-RING	SHCS
W36-8-8	W37-8-8	.50	1.813	2.125	.688	1.50	.75	1.000	.344	5/16-18	210	5/16-18X1.50
W36-12-12	W37-12-12	.75	2.063	2.563	.875	1.875	.75	1.250	.406	3/8-16	214	3/8-16X1.50
W36-16-16	W37-16-16	1.00	2.313	2.750	1.031	2.063	.88	1.560	.406	3/8-16	219	3/8-16X1.75
W36-20-20	W37-20-20	1.25	2.875	3.125	1.188	2.313	.94	1.750	.469	7/16-14	222	7/16-14X1.75
W36-24-24	W37-24-24	1.50	3.250	3.688	1.406	2.750	1.19	2.115	.531	1/2-13	225	1/2-13X2.25
W36-32-32	W37-32-32	2.00	3.813	4.000	1.688	3.063	1.44	2.490	.531	1/2-13	228	1/2-13X2.50
W36-40-40	W37-40-40	2.50	4.281	4.500	2.000	3.500	1.82	2.995	.531	1/2-13	232	1/2-13X2.75
W36-48-48	W37-48-48	3.00	5.156	5.313	2.438	4.188	2.19	3.615	.656	5/8-11	237	5/8-11X3.50
W36-56-56	W37-56-56	3.50	5.500	6.000	2.750	4.750	1.44	4.095	.656	5/8-11	241	5/8-11X2.75
W36-64-64	W37-64-64	4.00	6.00	6.38	3.062	5.125	1.44	4.595	.656	5/8-11	245	5/8-11X2.75
W36-80-80	W37-80-80	5.00	7.12	7.25	3.625	6.000	1.75	5.595	.656	5/8-11	253	5/8-11X3.00

CODE 62 BLANKING												
PART NO. O-RING FIG. 1	PART NO. FLAT FACE FIG. 2	PAD SIZE	A	B	C	D	E	F	G	H UNC-2B	MOUNTING HARDWARE	
											O-RING	SHCS
W38-8-8	W39-8-8	.500	1.94	2.30	.718	1.594	1.25	1.000	.344	5/16-18	210	5/16-18X2.00
W38-12-12	W39-12-12	.750	2.50	2.95	.937	2.000	1.25	1.250	.406	3/8-16	214	3/8-16X2.00
W38-16-16	W39-16-16	1.00	2.75	3.19	1.093	2.250	1.50	1.560	.492	7/16-14	219	7/16-14X2.50
W38-20-20	W39-20-20	1.25	3.06	3.75	1.250	2.625	1.43	1.750	.531	1/2-13	222	1/2-13X2.50
W38-24-24	W39-24-24	1.50	3.75	4.44	1.437	3.125	1.82	2.115	.656	5/8-11	225	5/8-11X3.00
W38-32-32	W39-32-32	2.00	4.50	5.25	1.750	3.812	1.82	2.490	.781	3/4-10	228	3/4-10X3.00
W38-40-40	W39-40-40	2.50	5.87	6.87	2.312	4.875	1.93	2.995	.906	7/8-9	232	7/8-9X3.50
W38-48-48	W39-48-48	3.00	7.00	8.50	2.812	6.000	2.69	3.615	1.190	1 1/8-7	237	1 1/8-7X4.50

FLOW, NEEDLE & CHECK VALVES

HYDRAULIC BALL VALVES

WELD COUPLINGS

FLANGES