

Figure 1

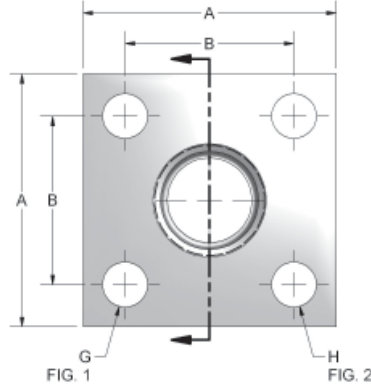

FIG. 1 FIG. 2

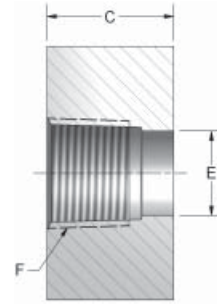
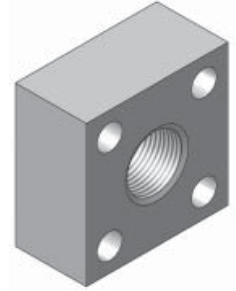

Figure 2



3000 SERIES SQUARE NPTF THREAD												
PART NO. O-RING FIG. 1	PART NO. FLAT FACE FIG. 2	PAD SIZE	A	B	C	D	E	F NPTF	G	H UNC-2B	MOUNTING HARDWARE	
											O-RING	SHCS
W65-12	W75-12	.75	2.25	1.438	1.25	1.250	.752	.75	.406	3/8-16	214	3/8-16X2.00
W65-16	W75-16	1.00	3.00	2.000	1.50	1.560	1.002	1.00	.531	1/2-13	219	1/2-13X2.25
W65-20	W75-20	1.25	3.00	2.000	1.50	1.750	1.252	1.25	.531	1/2-13	222	1/2-13X2.25
W65-24	W75-24	1.50	4.00	2.750	1.75	2.115	1.502	1.50	.656	5/8-11	225	5/8-11X2.75
W65-32	W75-32	2.00	4.00	2.750	1.75	2.490	2.002	2.00	.656	5/8-11	228	5/8-11X2.75
W65-40	W75-40	2.50	5.50	3.750	2.25	2.995	2.502	2.50	.906	7/8-9	232	7/8-9X3.50
W65-48	W75-48	3.00	5.50	3.750	2.25	3.615	3.002	3.00	.906	7/8-9	237	7/8-9X3.50

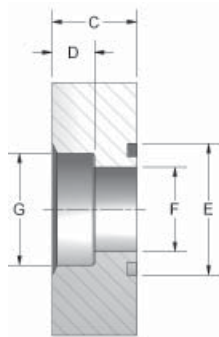

Figure 1

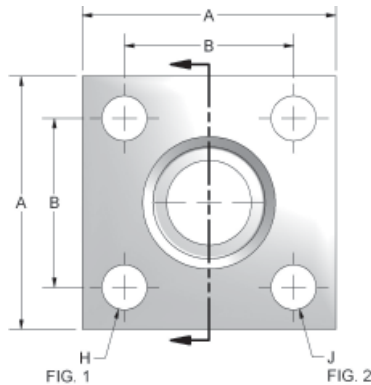

FIG. 1 FIG. 2

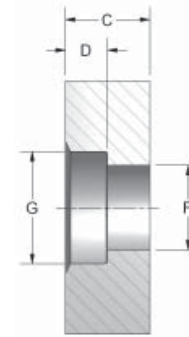
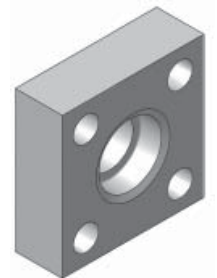

Figure 2



3000 SERIES SQUARE SOCKET WELD - PIPE													
PART NO. O-RING FIG. 1	PART NO. FLAT FACE FIG. 2	PAD SIZE	A	B	C	D	E	F	G	H	J UNC-2B	MOUNTING HARDWARE	
												O-RING	SHCS
W66-12	W76-12	.75	2.25	1.438	1.00	.50	1.250	.752	1.062	.406	3/8-16	214	3/8-16X1.75
W66-16	W76-16	1.00	3.00	2.000	1.00	.50	1.560	1.002	1.328	.531	1/2-13	219	1/2-13X1.75
W66-20	W76-20	1.25	3.00	2.000	1.00	.50	1.750	1.252	1.672	.531	1/2-13	222	1/2-13X1.75
W66-24	W76-24	1.50	4.00	2.750	1.25	.62	2.115	1.502	1.922	.656	5/8-11	225	5/8-11X2.25
W66-32	W76-32	2.00	4.00	2.750	1.25	.62	2.490	2.002	2.406	.656	5/8-11	228	5/8-11X2.25
W66-40	W76-40	2.50	5.50	3.750	1.50	.75	2.995	2.502	2.906	.906	7/8-9	232	7/8-9X2.75
W66-48	W76-48	3.00	5.50	3.750	1.50	.75	3.615	3.002	3.547	.906	7/8-9	237	7/8-9X2.75
W66-64	W76-64	4.00	7.00	5.000	2.00	.75	4.625	3.880	4.578	1.060	1-8	245	1-8X3.50

FLOW, NEEDLE & CHECK VALVES

HYDRAULIC BALL VALVES

WELD COUPLINGS

FLANGES