

FLOW, NEEDLE & CHECK VALVES

HYDRAULIC BALL VALVES

WELD COUPLINGS

FLANGES

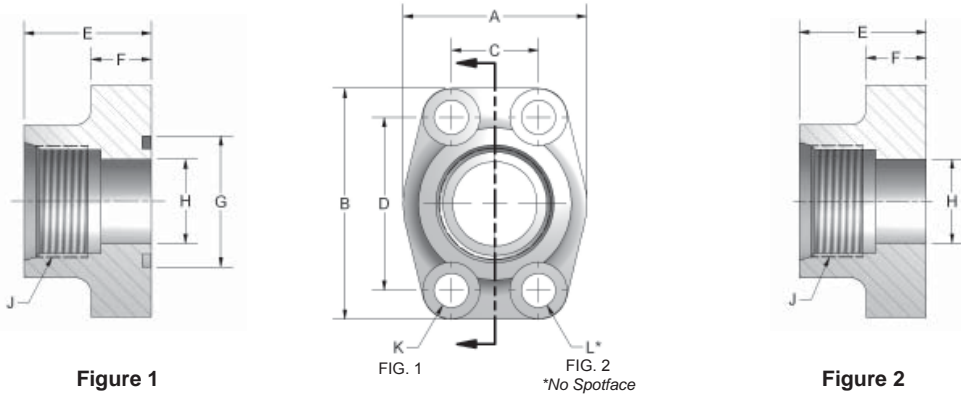

Figure 1

FIG. 1
FIG. 2
*No Spotface

Figure 2

CODE 61 SAE STRAIGHT THREAD																
PART NO. O-RING FIG. 1	PART NO. FLAT FACE FIG. 2	PORT SIZE	PAD SIZE	A	B	C	D	E	F	G	H	J UN/ UNF-2B	K	L UNC-2B	MOUNTING HARDWARE	
															O-RING	SHCS
W46-8-8	W106-8-8	.50	.50	1.81	2.13	.688	1.500	1.42	.63	1.000	.502	3/4-16	.344	5/16-18	210	5/16-18X1.25
W46-12-12	W106-12-12	.75	.75	1.97	2.56	.875	1.875	1.42	.71	1.250	.752	1 1/16-12	.406	3/8-16	214	3/8-16X1.50
W46-16-16	W106-16-16	1.00	1.00	2.17	2.75	1.031	2.062	1.50	.71	1.560	1.002	1 5/16-12	.406	3/8-16	219	3/8-16X1.50
W46-20-20	W106-20-20	1.25	1.25	2.68	3.12	1.188	2.312	1.61	.83	1.750	1.252	1 5/8-12	.469	7/16-14	222	7/16-14X1.75
W46-24-24	W106-24-24	1.50	1.50	3.07	3.66	1.406	2.750	1.77	.98	2.115	1.502	1 7/8-12	.531	1/2-13	225	1/2-13X1.75
*W46-32-32	W106-32-32	2.00	2.00	3.54	4.00	1.688	3.062	1.77	.98	2.490	2.002	2 1/2-12	.531	1/2-13	228	1/2-13X1.75

*NOTE: 500 PSI max for W46-32-32

CODE 62 SAE STRAIGHT THREAD																
PART NO. O-RING FIG. 1	PART NO. FLAT FACE FIG. 2	PORT SIZE	PAD SIZE	A	B	C	D	E	F	G	H	J UN/ UNF-2B	K	L UNC-2B	MOUNTING HARDWARE	
															O-RING	SHCS
W48-8-8	W49-8-8	.50	.50	1.81	2.21	.718	1.594	1.42	.63	1.000	.502	3/4-16	.344	5/16-18	210	5/16-18X1.25
W48-12-12	W49-12-12	.75	.75	2.17	2.80	.937	2.000	1.38	.83	1.250	.752	1 1/8-12	.406	3/8-16	214	3/8-16X1.50
W48-16-16	W49-16-16	1.00	1.00	2.56	3.19	1.093	2.250	1.65	.98	1.560	1.002	1 5/16-12	.492	7/16-14	219	7/16-14X1.75
W48-20-20	W49-20-20	1.25	1.25	3.07	3.75	1.250	2.625	1.77	1.06	1.750	1.252	1 5/8-12	.531	1/2-13	222	1/2-13X1.75
W48-24-24	W49-24-24	1.50	1.50	3.70	4.41	1.437	3.125	1.97	1.18	2.115	1.502	1 7/8-12	.656	5/8-11	225	5/8-11X2.25
W48-32-32	W49-32-32	2.00	2.00	4.50	5.28	1.750	3.812	2.56	1.46	2.490	2.002	2 1/2-12	.781	3/4-10	228	3/4-10X2.75