

Saddle Weld

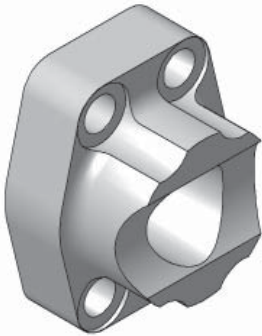

FLOW, NEEDLE & CHECK VALVES

HYDRAULIC BALL VALVES

WELD COUPLINGS

FLANGES

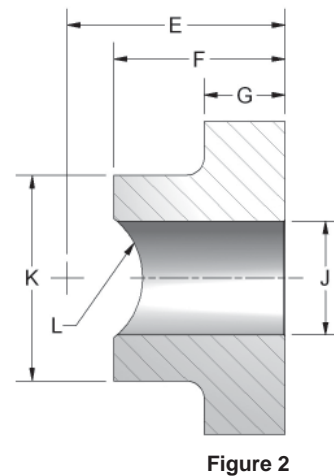
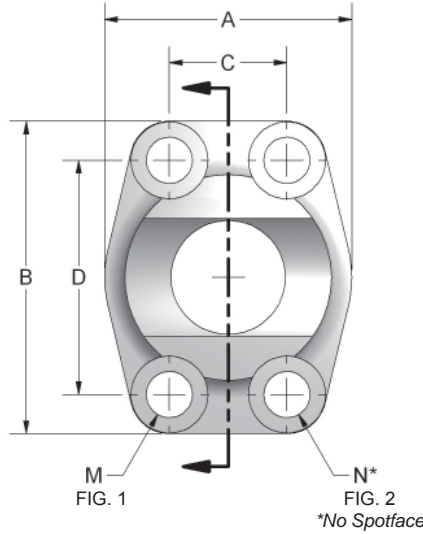
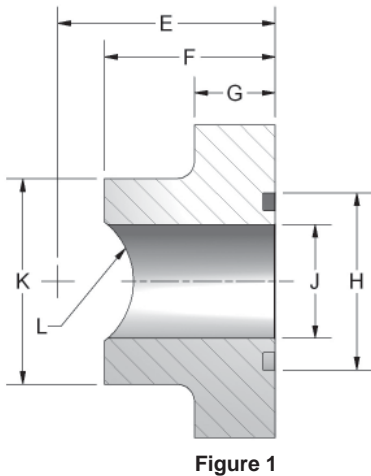

CODE 61 SADDLE WELD - PIPE

| PART NO. O-RING FIG. 1 | PART NO. FLAT FACE FIG. 2 | PIPE SIZE | PAD SIZE | A | B | C | D | E | F | G | H | J | K | L | M | N UNC-2B | MOUNTING HARDWARE | |
|------------------------------|---------------------------------|--------------|-------------|------|------|-------|-------|-------|------|-----|-------|-------|------|-------|------|-------------|----------------------|--------------|
| | | | | | | | | | | | | | | | | | O-RING | SHCS |
| W8-12-12 | W7-12-12 | .75 | .75 | 1.97 | 2.56 | .875 | 1.875 | 1.775 | 1.42 | .71 | 1.250 | .752 | 1.54 | .532 | .406 | 3/8-16 | 214 | 3/8-16X1.50 |
| W8-16-16 | W7-16-16 | 1.00 | 1.00 | 2.17 | 2.75 | 1.031 | 2.062 | 1.912 | 1.50 | .71 | 1.560 | 1.002 | 1.81 | .665 | .406 | 3/8-16 | 219 | 3/8-16X1.50 |
| W8-20-20 | W7-20-20 | 1.25 | 1.25 | 2.68 | 3.12 | 1.188 | 2.312 | 2.146 | 1.61 | .83 | 1.750 | 1.252 | 2.22 | .837 | .469 | 7/16-14 | 222 | 7/16-14X1.75 |
| W8-24-24 | W7-24-24 | 1.50 | 1.50 | 3.07 | 3.66 | 1.406 | 2.750 | 2.290 | 1.77 | .98 | 2.115 | 1.502 | 2.50 | .957 | .531 | 1/2-13 | 225 | 1/2-13X1.75 |
| W8-32-32 | W7-32-32 | 2.00 | 2.00 | 3.54 | 4.00 | 1.688 | 3.062 | 2.340 | 1.77 | .98 | 2.490 | 2.002 | 3.12 | 1.200 | .531 | 1/2-13 | 228 | 1/2-13X1.75 |
| W8-40-40 | W7-40-40 | 2.50 | 2.50 | 4.09 | 4.49 | 2.000 | 3.500 | 2.660 | 1.97 | .98 | 2.995 | 2.502 | 3.62 | 1.451 | .531 | 1/2-13 | 232 | 1/2-13X1.75 |

CODE 61 SADDLE WELD - TUBE

| PART NO. O-RING FIG. 1 | PART NO. FLAT FACE FIG. 2 | TUBE SIZE | PAD SIZE | A | B | C | D | E | F | G | H | J | K | L | M | N UNC-2B | MOUNTING HARDWARE | |
|------------------------------|---------------------------------|--------------|-------------|------|------|-------|-------|-------|------|-----|-------|-------|------|-------|------|-------------|----------------------|--------------|
| | | | | | | | | | | | | | | | | | O-RING | SHCS |
| W87-12-12 | W69-12-12 | .75 | .75 | 1.97 | 2.56 | .875 | 1.875 | 1.420 | 1.42 | .71 | 1.250 | .752 | 1.54 | .382 | .406 | 3/8-16 | 214 | 3/8-16X1.50 |
| W87-16-12 | W69-16-12 | 1.00 | .75 | 1.97 | 2.56 | .875 | 1.875 | 1.737 | 1.42 | .71 | 1.250 | .752 | 1.54 | .507 | .406 | 3/8-16 | 214 | 3/8-16X1.50 |
| W87-16-16 | W69-16-16 | 1.00 | 1.00 | 2.17 | 2.75 | 1.031 | 2.062 | 1.500 | 1.50 | .71 | 1.560 | 1.002 | 1.81 | .507 | .406 | 3/8-16 | 219 | 3/8-16X1.50 |
| W87-20-16 | W69-20-16 | 1.25 | 1.00 | 2.17 | 2.75 | 1.031 | 2.062 | 1.858 | 1.50 | .71 | 1.560 | 1.002 | 1.81 | .632 | .406 | 3/8-16 | 219 | 3/8-16X1.50 |
| W87-20-20 | W69-20-20 | 1.25 | 1.25 | 2.68 | 3.12 | 1.188 | 2.312 | 1.665 | 1.61 | .83 | 1.750 | 1.252 | 2.22 | .632 | .469 | 7/16-14 | 222 | 7/16-14X1.75 |
| W87-24-20 | W69-24-20 | 1.50 | 1.25 | 2.68 | 3.12 | 1.188 | 2.312 | 2.022 | 1.61 | .83 | 1.750 | 1.252 | 2.22 | .757 | .469 | 7/16-14 | 222 | 7/16-14X1.75 |
| W87-28-24 | W69-28-24 | 1.75 | 1.50 | 3.07 | 3.66 | 1.406 | 2.750 | 2.198 | 1.77 | .98 | 2.115 | 1.502 | 2.50 | .882 | .531 | 1/2-13 | 225 | 1/2-13X1.75 |
| W87-32-32 | W69-32-32 | 2.00 | 2.00 | 3.54 | 4.00 | 1.688 | 3.062 | 2.262 | 1.77 | .98 | 2.490 | 1.691 | 2.38 | 1.007 | .531 | 1/2-13 | 228 | 1/2-13X1.75 |
| W87-36-32 | W69-36-32 | 2.25 | 2.00 | 3.54 | 4.00 | 1.688 | 3.062 | 2.247 | 1.77 | .98 | 2.490 | 2.002 | 3.12 | 1.132 | .531 | 1/2-13 | 228 | 1/2-13X1.75 |