

CODE 61 90° JIC THREAD						
PART NO.	TUBE O.D.	FLANGE SIZE	A	B	C	THREAD
390-8-12	1/2	3/4	1.500	1.66	2.13	3/4-16
390-12-12	3/4	3/4	1.500	1.66	2.13	1 1/16-12
390-16-12	1	3/4	1.500	1.66	2.13	1 5/16-12
390-12-16	3/4	1	1.750	1.81	2.37	1 1/16-12
390-16-16	1	1	1.750	1.81	2.37	1 5/16-12
390-20-16	1 1/4	1	1.750	1.81	2.37	1 5/8-12
390-12-20	3/4	1 1/4	2.000	2.06	2.62	1 1/16-12
390-16-20	1	1 1/4	2.000	2.06	2.62	1 5/16-12
390-20-20	1 1/4	1 1/4	2.000	2.06	2.62	1 5/8-12
390-24-20	1 1/2	1 1/4	2.000	2.06	2.62	1 7/8-12
390-12-24	3/4	1 1/2	2.375	2.33	3.15	1 1/16-12
390-16-24	1	1 1/2	2.375	2.33	3.15	1 5/16-12
390-20-24	1 1/4	1 1/2	2.375	2.33	3.15	1 5/8-12
390-24-24	1 1/2	1 1/2	2.375	2.33	3.15	1 7/8-12
390-32-24	2	1 1/2	2.375	2.33	3.15	2 1/2-12
390-24-32	1 1/2	2	2.812	3.06	4.25	1 7/8-12
390-32-32	2	2	2.812	3.06	4.25	2 1/2-12
390-32-40	2	2 1/2	3.312	3.06	4.25	2 1/2-12

CODE 62 90° JIC THREAD						
PART NO.	TUBE O.D.	FLANGE SIZE	A	B	C	THREAD
690-8-8	1/2	1/2	1.250	1.66	2.13	3/4-16
690-8-12	1/2	3/4	1.625	1.66	2.13	3/4-16
690-12-12	3/4	3/4	1.625	1.66	2.13	1 1/16-12
690-16-12	1	3/4	1.625	1.66	2.13	1 5/16-12
690-12-16	3/4	1	1.875	1.81	2.37	1 1/16-12
690-16-16	1	1	1.875	1.81	2.37	1 5/16-12
690-20-16	1 1/4	1	1.875	1.81	2.37	1 5/8-12
690-16-20	1	1 1/4	2.125	2.06	2.76	1 5/16-12
690-20-20	1 1/4	1 1/4	2.125	2.06	2.76	1 5/8-12
690-24-20	1 1/2	1 1/4	2.125	2.19	2.76	1 7/8-12
690-20-24	1 1/4	1 1/2	2.500	2.33	3.15	1 5/8-12
690-24-24	1 1/2	1 1/2	2.500	2.33	3.15	1 7/8-12
690-32-24	2	1 1/2	2.500	3.06	4.25	2 1/2-12
690-24-32	1 1/2	2	3.125	3.06	4.25	1 7/8-12
690-32-32	2	2	3.125	3.06	4.25	2 1/2-12

90° ORFS Thread

CODE 61 90° ORFS THREAD						
PART NO.	TUBE O.D.	FLANGE SIZE	A	B	C	THREAD
394-12-12	3/4	3/4	1.500	1.66	2.13	1 3/16-12
394-16-12	1	3/4	1.500	1.66	2.13	1 7/16-12
394-12-16	3/4	1	1.750	1.81	2.37	1 3/16-12
394-16-16	1	1	1.750	1.81	2.37	1 7/16-12
394-20-16	1 1/4	1	1.750	1.81	2.37	1 11/16-12
394-16-20	1	1 1/4	2.000	2.06	2.62	1 7/16-12
394-20-20	1 1/4	1 1/4	2.000	2.06	2.62	1 11/16-12
394-24-20	1 1/2	1 1/4	2.000	2.06	2.62	2-12
394-20-24	1 1/4	1 1/2	2.375	2.33	3.15	1 11/16-12
394-24-24	1 1/2	1 1/2	2.375	2.33	3.15	2-12
394-24-32	1 1/2	2	2.812	3.06	4.25	2-12

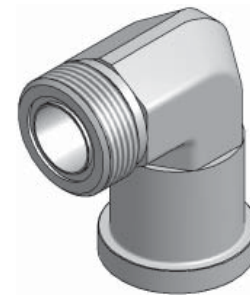
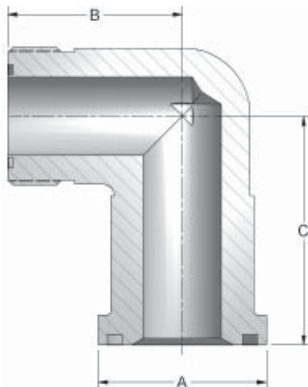

CODE 62 90° ORFS THREAD						
PART NO.	TUBE O.D.	FLANGE SIZE	A	B	C	THREAD
694-12-8	3/4	1/2	1.250	1.66	2.13	1 3/16-12
694-12-12	3/4	3/4	1.625	1.66	2.13	1 3/16-12
694-16-12	1	3/4	1.625	1.66	2.13	1 7/16-12
694-12-16	3/4	1	1.875	1.81	2.37	1 3/16-12
694-16-16	1	1	1.875	1.81	2.37	1 7/16-12
694-20-16	1 1/4	1	1.875	1.81	2.37	1 11/16-12
694-16-20	1	1 1/4	2.125	2.06	2.76	1 7/16-12
694-20-20	1 1/4	1 1/4	2.125	2.06	2.76	1 11/16-12
694-24-20	1 1/2	1 1/4	2.125	2.06	2.76	2-12
694-20-24	1 1/4	1 1/2	2.500	2.33	3.15	1 11/16-12
694-24-24	1 1/2	1 1/2	2.500	2.33	3.15	2-12
694-24-32	1 1/2	2	3.125	3.06	4.25	2-12