

Figure 1

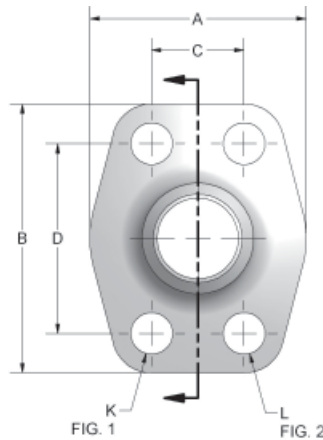

FIG. 1 FIG. 2

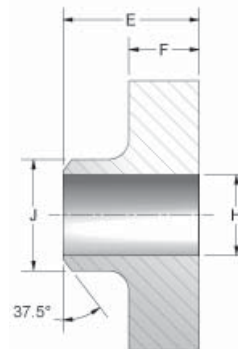
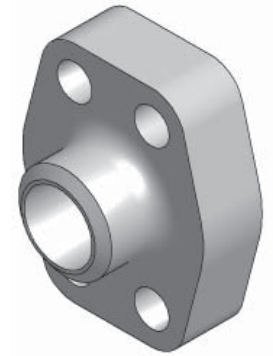

Figure 2



FLOW, NEEDLE & CHECK VALVES

HYDRAULIC BALL VALVES

WELD COUPLINGS

FLANGES

CODE 62 BUTT WELD - SCHEDULE 80 PIPE

PART NO. O-RING FIG. 1	PART NO. FLAT FACE FIG. 2	PIPE SIZE	PAD SIZE	A	B	C	D	E	F	G	H	J	K	L UNC-2B	MOUNTING HARDWARE	
															O-RING	SHCS
W28-8	W26-8	.50	.50	1.81	2.21	.718	1.594	1.42	.63	1.000	.548	.840	.344	5/16-18	210	5/16-18X1.25
W28-12	W26-12	.75	.75	2.17	2.80	.937	2.000	1.38	.83	1.250	.744	1.050	.406	3/8-16	214	3/8-16X1.50
W28-16	W26-16	1.00	1.00	2.56	3.19	1.093	2.250	1.61	.83	1.560	.959	1.315	.492	7/16-14	219	7/16-14X1.75
W28-20	W26-20	1.25	1.25	3.07	3.75	1.250	2.625	1.73	.98	1.750	1.280	1.660	.531	1/2-13	222	1/2-13X1.75
W28-24	W26-24	1.50	1.50	3.70	4.41	1.437	3.125	2.17	1.18	2.115	1.502	1.900	.656	5/8-11	225	5/8-11X2.25
W28-32	W26-32	2.00	2.00	4.50	5.28	1.750	3.812	2.56	1.46	2.490	1.941	2.375	.781	3/4-10	228	3/4-10X3.00
*W28-40	*W26-40	2.50	2.50	5.00	6.88	2.312	4.875	2.37	1.50	2.995	2.325	2.875	.940	7/8-9	232	7/8-9X3.00
*W28-48	*W26-48	3.00	3.00	6.00	8.50	2.812	6.000	2.96	2.00	3.615	2.902	3.500	1.190	1 1/8-7	237	1 1/8-7X4.00

CODE 62 BUTT WELD - SCHEDULE 160 PIPE

PART NO. O-RING FIG. 1	PART NO. FLAT FACE FIG. 2	PIPE SIZE	PAD SIZE	A	B	C	D	E	F	G	H	J	K	L UNC-2B	MOUNTING HARDWARE	
															O-RING	SHCS
W30-8	W29-8	.50	.50	1.81	2.21	.718	1.594	1.42	.63	1.000	.466	.840	.344	5/16-18	210	5/16-18X1.25
W30-12	W29-12	.75	.75	2.17	2.80	.937	2.000	1.38	.83	1.250	.614	1.050	.406	3/8-16	214	3/8-16X1.50
W30-16	W29-16	1.00	1.00	2.56	3.19	1.093	2.250	1.61	.83	1.560	.817	1.315	.492	7/16-14	219	7/16-14X1.75
W30-20	W29-20	1.25	1.25	3.07	3.75	1.250	2.625	1.73	.98	1.750	1.162	1.660	.531	1/2-13	222	1/2-13X1.75
W30-24	W29-24	1.50	1.50	3.70	4.41	1.437	3.125	2.17	1.18	2.115	1.340	1.900	.656	5/8-11	225	5/8-11X2.25
W30-32	W29-32	2.00	2.00	4.50	5.28	1.750	3.812	2.56	1.46	2.490	1.689	2.375	.781	3/4-10	228	3/4-10X3.00
*W30-40	*W29-40	2.50	2.50	5.00	6.88	2.312	4.875	2.37	1.50	2.995	2.127	2.875	.940	7/8-9	232	7/8-9X3.00
*W30-48	*W29-48	3.00	3.00	6.00	8.50	2.812	6.000	2.96	2.00	3.615	2.626	3.500	1.190	1 1/8-7	237	1 1/8-7X4.00

CODE 62 BUTT WELD - SCHEDULE XXS PIPE

PART NO. O-RING FIG. 1	PART NO. FLAT FACE FIG. 2	PIPE SIZE	PAD SIZE	A	B	C	D	E	F	G	H	J	K	L UNC-2B	MOUNTING HARDWARE	
															O-RING	SHCS
W33-8	W32-8	.50	.50	1.81	2.21	.718	1.594	1.42	.63	1.000	.254	.840	.344	5/16-18	210	5/16-18X1.25
W33-12	W32-12	.75	.75	2.17	2.80	.937	2.000	1.38	.83	1.250	.436	1.050	.406	3/8-16	214	3/8-16X1.50
W33-16	W32-16	1.00	1.00	2.56	3.19	1.093	2.250	1.61	.83	1.560	.601	1.315	.492	7/16-14	219	7/16-14X1.75
W33-20	W32-20	1.25	1.25	3.07	3.75	1.250	2.625	1.73	.98	1.750	.898	1.660	.531	1/2-13	222	1/2-13X1.75
W33-24	W32-24	1.50	1.50	3.70	4.41	1.437	3.125	2.17	1.18	2.115	1.102	1.900	.656	5/8-11	225	5/8-11X2.25
W33-32	W32-32	2.00	2.00	4.50	5.28	1.750	3.812	2.56	1.46	2.490	1.505	2.375	.781	3/4-10	228	3/4-10X3.00
*W33-40	*W32-40	2.50	2.50	5.00	6.88	2.312	4.875	2.37	1.50	2.995	1.773	2.875	.940	7/8-9	232	7/8-9X3.00
*W33-48	*W32-48	3.00	3.00	6.00	8.50	2.812	6.000	2.96	2.00	3.615	2.302	3.500	1.190	1 1/8-7	237	1 1/8-7X4.00

*Flange Shape Rectangle
3000 PSI Max Working Pressure